



MOHAVE COUNTY DEVELOPMENT SERVICES

P. O. Box 7000 Kingman, Arizona 86402-7000 3250 E. Kino Ave, Kingman www.mohave.gov Telephone (928) 757-0903

Scott Holtry
Department Director

J. David Strahl
County Manager

NOTICE OF INTENT TO DISCHARGE ON-SITE WASTEWATER TREATMENT FACILITY INSTRUCTIONS

Submit Notice of Intent to Discharge (NOI) to obtain authorization to construct and operate a septic tank and disposal field under a Type 4.02-4.22 General Aquifer Protection Permit in accordance with **Arizona Administrative Code (A.A.C.) R18-9-Article 3**.

The following must be submitted to complete an application for an onsite wastewater treatment facility. **Payment is due at the time of submittal** and is not refundable, permits are not transferable.

Requirements for submitting a complete on-site wastewater application must include:

- Mohave County Permit Application Worksheet
- Notice of Intent to Discharge
- Fixture Count Calculation Chart Worksheet
- Design Configuration Sheet
- Draft Operation and Maintenance Manual (Alternative Systems Only)
- On-site Wastewater Facility Plot Plan ****Use Engineer's Scale – MAX. 1 inch = 60 feet****
- Site Plan (Commercial Only)
- Sewer Availability Sheet
- Temporary Agreement
- List of Materials and Components for constructing the on-site wastewater facility
- Property Floodplain Information Sheet (PFI)
- Site Investigation Report

GENERAL APPLICATION PROCESS

The application will be reviewed to ensure it is administratively complete. Then reviewed for technical compliance. Once all requirements have been met, a Construction Authorization (CA) will be issued to the applicant. CA must be signed and returned, then construction may begin of the on-site wastewater facility.

****Alternative & Commercial Systems must be installed by a contractor licensed for this type of work****
Construction **MUST** be completed, and a Request for Discharge Authorization (RDA) must be submitted within **2 years** to request an inspection of the facility. **The following must be submitted with the RDA:**

1. RDA form with Certification that the septic tank passed watertightness test after installation.
2. Final as-built plot plan of the project if it differs from the proposed plan.
3. Certificate of Completion or (ECC) (Alternative Systems Only)

When the above documents are received, an inspector will inspect the facility. If the facility was constructed according to the approved plan in compliance with all applicable State laws and local regulations, a Discharge Authorization (DA) will be issued.

FEES

Fees for Type 4 General Permits (4.02 through 4.22) are listed on website: [Mohave County Septic Permitting](#)

If an applicant requests priority review, the Department shall approve or deny the request. The Department will only consider requests where environmental nuisances of occupied properties exist. The request must be accompanied by a failed NAWT inspection report. When determining whether to approve a priority review request The Department shall consider the complexity of the project and the Department's current workload.

LICENSING TIME FRAMES

Licensing Time Frames (LTFs) are specified by the Arizona Department of Environmental Quality in A.A.C. R18-1-525. The following LTFs limit the number of business days ADEQ can review your project without a penalty:

License Type	Administrative Completeness Review	Substantive Review	Overall Time Frame
Single 4.02, 4.03, 4.13, and 4.14 General Permits	42	31	73
Combined Two or Three Type 4 General Permits	42	53	95
Combined Four or More Type 4 General Permits	42	94	136

- Each request for an alternative design, installation, or operational feature under A.A.C. R18-9-A312(G) to a type 4 general permit adds eight business days to the substantive review timeframe.

Notes:

1. Construction of the facility CANNOT take place until the Construction Authorization is issued.
2. Discharge CANNOT take place until the Discharge Authorization is issued.
3. If the construction differs from the proposed plan, and a second inspection and/or second review of the system is necessary, additional fees may apply.
4. A Sewer Availability Information Sheet is required from the sewer provider for the property location. This **MUST** be done **PRIOR** to having a site investigation and must be attached to the application submittal.

<h2 style="margin: 0;">Mohave County</h2> <h3 style="margin: 0;">Onsite Wastewater Treatment Facility</h3> <h3 style="margin: 0;">Permit Application Worksheet</h3>	Date _____ Project # _____ Permit # _____	
---	---	---

PLOT PLANS MUST BE NO LARGER THAN 8 1/2 " X 11"

NOTE: Shaded areas are for county use only.

1. Type of Improvement: _____ 2. Applicant's name: _____ Mailing address: _____ City: _____ State: _____ Zip: _____ 2A. Contact Name: _____ PHONE: _____ Fax Number: _____ Email: _____ 3. Property Owners Name: _____ Mailing Address: _____ City: _____ State: _____ Zip: _____ Fax Number: _____ Email: _____ 4. SITE LOCATION ADDRESS: _____ House No Street Dir Street Name: 5. <u>Legal Description:</u> Assessor Parcel Number: _____ - _____ - _____ Parent Parcel: <input type="checkbox"/> Yes Subdivision Name: _____ Corner Lot: <input type="checkbox"/> Yes Unit/Tract/Block/Lot: _____ -- _____ -- _____ Township/Range/Section: _____ -- _____ -- _____ 6. Plot Plan Drawing (see instructions on plot plan form)	
--	--

<p>Public Works, Flood Control Division</p> 7. Is there an existing structure? <input type="checkbox"/> YES <input type="checkbox"/> NO 7A. Previous PFI#: _____ Previous FUP#: _____	
---	--

<p>Environmental Quality Division</p> 8. Is this an existing system? <input type="checkbox"/> YES <input type="checkbox"/> NO 8A. Is this a Conventional Septic? <input type="checkbox"/> YES <input type="checkbox"/> NO, Alternative System? <input type="checkbox"/> YES <input type="checkbox"/> NO 9. Septic Tank Size: _____ Manufacturer: _____ 10. Septic Contractor: _____ License #: _____ Or Owner / Builder: <input type="checkbox"/> YES <input type="checkbox"/> NO	Number of bedrooms: _____ Number of fixture units: _____
--	---

<p>Planning & Zoning Division</p> 12. Zoning: _____	
	BAL DUE \$ _____

GENERAL INFORMATION

1 Project Name

Project Name _____

2 Applicant (person responsible for overall compliance)

(Check One) Owner Operator

3 Site Information

Location of proposed tank site _____

Latitude _____° _____' _____" N Longitude _____° _____' _____" W

Legal Description of Property _____

Water Supply (check one):

- Public Water
- Private Well *See Note may require letter
- Haul Water *See Note may require letter

Wash or drainage easement: If system is proposed within the 50-foot setback required by the Aquifer Protection Permit, a letter must be obtained from the appropriate flood plain administrator allowing a reduction of the setback.

If applicable a letter from floodplain administrator must be included in the application packet.

4 Existing Environmental Permits

List any other federal or state environmental permits issued for or needed by the facility, including any individual permit, Groundwater Quality Protection Permit, or Notice of Disposal that may have previously authorized the discharge (attach additional pages if necessary).

5 Review Fees

- Standard Review Fee (See Instructions)
- Request for priority review for this NOI and include failed NAWT Inspection report.

SUPPLEMENTAL INFORMATION

6 Information and Submission Requirements (Check All Completed Items)

- Site Investigation Report per A.A.C. R18-9-A309(B)(1)
- Site Plan per A.A.C. R18-9-A309(B)(2)

7 Design Flow and Strength of Wastewater

- A) Design flow per A.A.C. R18-9-A309(B)(3) _____ gallons per day. Soil Absorption Rate (SAR) _____ gallons per day.
- B) The expected strength of the wastewater (if the strength exceeds the levels for typical sewage) is attached? Yes

Residential

For single family dwelling, a list of the number of bedrooms and plumbing fixtures and corresponding unit flows used to calculate the design flow of the facility per A.A.C. R18-9-A314

Wastewater Source	Number	Unit Flows used to calculate the design flow of the facility
Bedrooms		
Plumbing Fixtures		

Commercial (or dwelling over 8 bedrooms or 56 fixture units)

For a dwelling other than for a single family, a list of each wastewater source and corresponding unit flows used to calculate the design flow of the facility. (See Table 1)

Wastewater Source	Number	Unit Flows used to calculate the design flow of the facility

8 List of Materials and Components

A list of material and components for constructing the onsite wastewater treatment facility is attached? Yes

*Public Water note: If no public water is available, and system is located less than 50 ft. from any property line, applicant must obtain an agreement from the owners of any affected undeveloped adjacent property to limit the location of any new well on their property to at

least 100 feet from the proposed treatment works and primary and reserve disposal works. The agreement must be recorded appropriately, and the documentation must be approved by the Department.

9 Selected General Permits (Check All General Permits that Are being Applied for)

Alternative Request(s) are attached (A.A.C. R18-9-A312(G))

Please indicate how many A312G requests are attached _____ .

4.02 Septic Tank with Disposal by Trench, Bed, Chamber Technology, or EZ Flow. Less than 3,000 Gallons per Day (GPD) Daily Flow

- A) This on-site wastewater treatment facility consists of a conventional septic tank system and disposal field sized for a design flow of _____ gallons per day. The septic tank conveys wastewater to a disposal field consisting of (check one):
1. Trench
 - a. Filled with aggregate [A.A.C. R18-9-101(1)], or
 - b. Filled with crushed, recycled concrete [A.A.C. R18-9-E302(C)(2)(d)]
 2. Bed
 3. Chamber technology
 4. EZFlow
- B) The date the system is expected to start operation _____.
- C) The sewage to the septic tank has the characteristics of Typical household sewage or Typical household sewage and _____.
- D) This on-site wastewater treatment facility is for (check one):
- Conventional septic tank system serving a single-family residence.
 - Conventional septic tank system serving other than a single-family residence.

4.03 Composting Toilet, Less than 3,000 GPD Daily Flow (Please select from Product List)

- A) Composting toilet system manufacturer name _____
- B) Composting toilet system manufacturer address _____
- C) A copy of the manufacturer's warranty, and the specifications for installation, operation, and maintenance has been provided? Yes
- D) The product model number _____
- E) Calculations for the composting rate, capacity, and waste accumulation volume are attached? Yes
- F) Documentation of listing by a national listing organization indicating that the composting toilet meets the stated manufacturer's specifications for loading, treatment performance, and operation has been attached (unless the composting toilet is listed under R18-9-A309(E) or is a component of a reference design approved by the Department)? Yes
- G) Describe the vector control method.
- H) Describe the planned method and frequency for disposing of the composted human excrement residue.
- I) Describe the planned method for disposing of the drainage from the composting unit.
- J) The number of bedrooms in the dwelling or persons served on a daily basis, as applicable. _____
- K) What is the corresponding design flow of the disposal works for the wastewater? _____
- L) The results from soil evaluation or percolation testing that adequately characterize the soils into which the wastewater will be dispersed and the locations of soil evaluation and percolation testing on the site plan have been provided? Yes
- M) The design for the disposal including the location of the interceptor, the location and configuration of the trench or bed used for wastewater dispersal, the location of connecting wastewater pipelines, and the location of the reserve area has been provided? Yes

4.04 Pressure Distribution System, Less than 3,000 GPD Daily Flow

- A) A copy of operation, maintenance, and warranty materials for the principal components has been attached? Yes
- B) A copy of dosing specifications, including pump curves, dispersing component curves, and float switch settings is attached? Yes

4.05 Gravelless Trench, Less than 3,000 GPD Daily Flow

- A) The soil absorption area that would be required if a conventional disposal trench filled with aggregate was used at the site? Yes

- B) The configuration and size of the proposed gravelless disposal field is attached? Yes
- C) The manufacturer's installation instructions and warranty of performance for absorbing wastewater into the native soil is attached? Yes

4.06 Natural Seal Evaporative Bed, Less than 3,000 GPD daily Flow

- A) Capillary rise potential test results for the media used to fill the evapotranspiration bed, unless sand meeting a D50 of 0.1 millimeter (50 percent by weight of grains equal to or smaller than 0.1 millimeter) is used? Yes
- B) Water mass balance calculations were used to size the evapotranspiration bed? Yes

4.07 Lined Evapotranspiration Bed, Less than 3,000 GPD Daily Flow

- A) Capillary rise potential test results for the media used to fill the evapotranspiration bed, unless sand meeting a D50 of 0.1 millimeter (50 percent by weight of grains equal to or smaller than 0.1 millimeter) is used? Yes
- B) Water mass balance calculations were used to size the evapotranspiration bed? Yes

4.08 Wisconsin Mound, Less than 3,000 GPD Daily Flow

- A) Specifications for the internal wastewater distribution system media proposed for use in the mound are attached? Yes
- B) Two scaled or dimensioned cross sections of the mound (one of the shortest basal area footprint dimension and one of the lengthwise dimension) are attached? Yes
- C) Design calculations following the "Wisconsin Mound Soil Absorption System: Siting, Design, and Construction Manual," published by the University of Wisconsin - Madison, January 1990 Edition have been provided? Yes

4.09 Engineered Pad, Less than 3,000 GPD Daily Flow

- A) Design materials and construction specifications for the engineered pad system are attached? Yes

4.10 Intermittent Sand Filter, Less than 3,000 GPD Daily Flow

- A) Specifications for the media proposed for use as the sand filter are attached? Yes

4.11 Peat Filter, Less than 3,000 GPD Daily Flow (Please select from Product List)

- A) Specifications for the peat media proposed for use in the filter or provided in the peat module, including the porosity, surface area, and moisture content are attached? Yes
- B) A statement indicating whether the peat is air dried, and whether the peat is from sphagnum moss or bog cotton is attached? Yes
- C) A description of the degree of decomposition is attached? Yes
- D) Specifications for installing the peat media are attached? Yes
- E) If a peat module is used, the name and address of the manufacturer, the model number, and a copy of the manufacturer's warranty are attached? Yes

4.12 Textile Filter, Less than 3,000 GPD Daily Flow (Please select from Product List)

- A) Filter manufacturer name _____
- B) Filter manufacturer address _____
- C) Filter model number _____
- D) A copy of the manufacturer's filter warranty is attached? Yes
- E) If the system is for nitrogen reduction to 15 milligrams per liter, five-month arithmetic mean, specifications on the nitrogen reduction performance of the filter system, and corroborating third-party test data is attached? Yes
- F) The manufacturer's operation and maintenance recommendations to achieve a 20-year life are attached? Yes
- G) If a pump or aerator is required for proper operation, the pump or aerator model number and a copy of the manufacturer's warranty is attached? Yes
- H) The design report has demonstrated there is adequate storage for untreated wastewater above the high operating level for a 24-hour period per AAC R18-9-E312 (B)(4)(e)? Yes
- I) The design provides fail-safe wastewater controls or operational processes to prevent the release of inadequately treated wastewater per AAC R18-9-E312 (B)(4)(g)? Yes

4.13 Denitrifying System Using Separated Wastewater Streams, Less than 3,000 GPD Daily Flow

4.14 Sewage Vault, Less than 3,000 GPD Daily Flow

4.15 Aerobic System, Less than 3,000 GPD Daily Flow (Please select from Product List)

- A) Aerobic system manufacturer name _____
- B) Aerobic system manufacturer address _____
- C) Aerobic system model number _____
- D) Evidence of performance specified in AAC R18-9-E315(B) has been attached? Yes
- E) A copy of the manufacturer's warranty and operation and maintenance recommendations to achieve performance for a 20-year life has been attached? Yes
- F) If the aerobic system will be used for nitrogen removal from the wastewater, has evidence of a valid product listing under R18-9-E309(E) indicating nitrogen removal performance, or specifications and third-party test data corroborating nitrogen reduction to the intended level been provided? Yes

- G) A list of pretreatment components needed to meet performance requirements has been attached? Yes
- H) The design report has demonstrated there is adequate storage for untreated wastewater above the high operating level for a 24-hour period per AAC R18-9-E312 (B)(4)(e)? Yes
- I) The design provides fail-safe wastewater controls or operational processes to prevent the release of inadequately treated wastewater per AAC R18-9-E312 (B)(4)(g)? Yes

4.16 Nitrate-Reactive Media Filter, Less than 3,000 GPD Daily Flow (Please select from Product List)

- A) Filter manufacturer name _____
- B) Filter manufacturer address _____
- C) Filter model number _____
- D) The manufacturer's requirements for pretreated wastewater supplied to the nitrate-reactive media filter have been attached? Yes
- E) The manufacturer's specifications for design, installation, and operation for the nitrate-reactive media filter system and appurtenances have been attached? Yes
- F) The manufacturer's warranty for the nitrate-reactive media filter system and appurtenances has been attached? Yes
- G) The manufacturer's operation and maintenance recommendations to achieve a 20-year operational life for the nitrate-reactive media filter system and appurtenances have been attached? Yes
- H) The manufacturer name and model number for all appurtenances that significantly contribute to achieving the performance have been attached? Yes

4.17 Cap System, Less than 3,000 GPD Daily Flow

- A) The specifications for the proposed cap fill material have been attached? Yes

4.18 Constructed Wetlands, Less than 3,000 GPD Design Flow

4.19 Sand Lined Trench, Less than 3,000 GPD Design Flow

- A) Specifications for the proposed media in the trench are attached? Yes

4.20 Disinfection Devices, Less than 3,000 GPD Design Flow

4.21 Surface Disposal, Less than 3,000 GPD Design Flow

4.22 Subsurface Drip Irrigation, Less than 3,000 GPD Design Flow

- A) Documentation of the pretreatment method proposed to achieve the wastewater criteria specified in AAC R18-9- A322(B)(1), such as the type of pretreatment system and the manufacturer's warranty is attached? Yes
- B) Initial filter and drip irrigation flushing settings are attached? Yes
- C) Calculations of the site evaporation rate are attached? Yes
- D) If supplemental irrigation water is introduced to the subsurface drip irrigation disposal works, an identification of the cross-connection controls, backflow controls, and supplemental water sources are attached? Yes

10 Additional On-site Requirements (for Type 4.03 through 4.22 General Permits)

- A) For a facility that includes treatment or disposal works permitted under a Type 4.03 to 4.22 General Aquifer Protection Permits (A.A.C. R18-9-E303 through R18-9-E323):
 - 1) Construction quality drawings that show the items listed in A.A.C. R18-9-A309(B)(6)(a) is attached? Yes
 - 2) Per A.A.C R18-9-A309(B)(6)(b) and R18-9-A313(B), a draft operation and maintenance manual for the on-site wastewater treatment facility consisting of the tasks and schedules for operating and maintaining performance over a 20-year operational life is attached? Yes

11 Alternative treatment works or disposal works

- Owner has provided signed statement form acknowledging use of an alternative treatment works or disposal works in lieu of a conventional treatment works or disposal works.

12 Certification (to be completed by Applicant on Permit Application Worksheet)

I, _____, certify that this Notice of Intent to Discharge and all attachments were prepared under my direction or authorization and all information is, to the best of my knowledge, true, accurate and complete. I also certify that the on-site wastewater treatment facility described in this form is or will be designed, constructed, and operated in accordance with the terms and conditions the General Aquifer Protection Permit(s) (A.A.C. R18-9-E302 through R18-9-E323) and applicable requirements of Arizona Revised Statutes Title 49, Chapter 2, and Arizona Administrative Code Title 18, Chapter 9 regarding Aquifer Protection Permits. I am aware that there are significant penalties for submitting false information including permit revocation as well as the possibility of fine and imprisonment for knowing violations.

Signature _____
Date

FOR RESIDENTIAL USE
FIXTURE COUNT CALCULATION CHART

Use the fixture count chart below to determine the total number of fixture units in the home. **Check the corresponding box on the system design flow chart based on your fixture count or number of bedrooms whichever is greater.** The box that is checked is the row where you'll find your minimum tank size and system design flow. Enter the information at the bottom of the page, and submit this form with your application.

Residential Fixture Type	Existing # Fixtures	Proposed # Fixtures	Multiply by	Fixture Units	Equals	Total # PROPOSED Fixtures
Bathtub			X	2	=	
Bidet			X	2	=	
Dishwasher, outside kitchen			X	2	=	
Clothes washer			X	2	=	
Utility tub or sink separate from clothes washer			X	2	=	
Kitchen Sink (may include dishwasher)			X	2	=	
Shower, single stall			X	2	=	
Sink, bar			X	1	=	
Sink, service			X	3	=	
Lavatory, single or double (bathroom sink)			X	1	=	
*Toilet, 1.6 gallons per flush (gpf)			X	3	=	
*Toilet, 1.6 - 3.2 gpf			X	4	=	
*Toilet >3.2 gpf			X	6	=	
FIXTURE COUNT TOTAL					=	
Physical # Bedrooms					=	

*Toilets currently available in Arizona are 1.6 gallons per flush. Older fixtures may not use the same amount of gallons per flush.

SYSTEM DESIGN FLOW CHART

✓	No. of Bedrooms	Fixture Count	Minimum Tank Size (gallons)	System Design Flow (gpd)
<input type="checkbox"/>	1	7 or less	1000	150
<input type="checkbox"/>		More than 7 less than 14	1000	300
<input type="checkbox"/>	2	14 or less	1000	300
<input type="checkbox"/>		More than 14 less than 21	1000	450
<input type="checkbox"/>	3	21 or less	1000	450
<input type="checkbox"/>		More than 21 less than 28	1250	600
<input type="checkbox"/>	4	28 or less	1250	600
<input type="checkbox"/>		More than 28 less than 35	1500	750
<input type="checkbox"/>	5	35 or less	1500	750
<input type="checkbox"/>		More than 35 less than 42	2000	900
<input type="checkbox"/>	6	42 or less	2000	900
<input type="checkbox"/>		More than 42 less than 49	2500	1050
<input type="checkbox"/>	7	49 or less	2500	1050
<input type="checkbox"/>		More than 49 less than 56	3000	1200
<input type="checkbox"/>	8*	56 or less	3000	1200
<input type="checkbox"/>		More than 56*	3000	1350

***NOTE: For a single residence with more than 8 bedrooms or more than 56 fixture units, use R18-9-A314 (D) (2) as the basis for determining minimum septic tank size and system design flow.**

For Commercial Use

(or dwelling over 8 bedrooms or 56 fixture units)

Wastewater Source	Applicable Unit	Sewage Design Flow per Applicable Unit.
Airport	Passenger (average daily number)	4
	Employee	15
Auto Wash	Facility	Per manufacturer, if consistent with this
Bar/Lounge	Seat	30
Barber Shop	Chair	35
Beauty Parlor	Chair	100
Bowling Alley (snack bar only)	Lane	75
Camp		
Day camp, no cooking facilities	Camping unit	30
Campground, overnight, flush toilets	Camping unit	75
Campground, overnight, flush toilets and	Camping unit	150
Campground, luxury	Person	100-150
Camp, youth, summer, or seasonal	Person	50
Church		
Without kitchen	Person (maximum attendance)	5
With kitchen	Person (maximum attendance)	7
Country Club	Resident Member	100
	Nonresident Member	10
Dance Hall	Patron	5
Dental Office	Chair	500
Dog Kennel	Animal, maximum occupancy	15
Dwelling		
For determining design flow for sewage treatment facilities under R18-9-B202(A)(9)(a) and sewage collection systems under R18-9-E301(D) and R18-9-B301(K), excluding peaking factor.	Person	80
Dwelling		
For on-site wastewater treatment facilities per R18-9-E302 through R18-9-E323:		
Apartment Building		
1 bedroom	Apartment	200
2 bedroom	Apartment	300
3 bedroom	Apartment	400
4 bedroom	Apartment	500
Seasonal or Summer Dwelling (with recorded seasonal occupancy restriction)	Resident	100
Single Family Dwellings	see R18-9-A314(D)(1)	see R18-9-A314(D)(1)
Other than Single Family Dwelling, the greater flow value based on:		
Bedroom count		
1-2 bedrooms	Bedroom	300
Each bedroom over 2	Bedroom	150
Fixture count	Fixture unit	25
Fire Station	Employee	45
Hospital		
All flows	Bed	250
Kitchen waste only	Bed	25
Laundry waste only	Bed	40
Hotel/motel		
Without kitchen	Bed (2 person)	50
With kitchen	Bed (2 person)	60

Department of Environmental Quality – Water Pollution Control

Industrial facility Without showers	Employee	25
With showers	Employee	35
Cafeteria, add	Employee	5
Institutions Resident	Person	75
Nursing home	Person	125
Rest home	Person	125
Laundry Self service	Wash cycle	50
Commercial	Washing machine	Per manufacturer, if consistent with this Chapter
Office Building	Employee	20
Park (temporary use) Picnic, with showers, flush toilets	Parking space	40
Picnic, with flush toilets only	Parking space	20
Recreational vehicle, no water or sewer	Vehicle space	75
Recreational vehicle, with water and sewer connections	Vehicle space	100
Mobile home/Trailer	Space	250
Restaurant/Cafeteria With toilet, add	Employee	20
Kitchen waste, add	Customer	7
Garbage disposal, add	Meal	6
Cocktail lounge, add	Meal	1
Kitchen waste disposal service, add	Customer	2
	Meal	2
Restroom, public	Toilet	200
School Staff and office	Person	20
Elementary, add	Student	15
Middle and High, add	Student	20
with gym & showers, add	Student	5
with cafeteria, add	Student	3
Boarding, total flow	Person	100
Service Station with toilets	First bay	1000
	Each additional bay	500
Shopping Center, no food or laundry	Square foot of retail space	0.1
Store Public restroom, add	Employee	20
	Square foot of retail space	0.1
Swimming Pool, Public	Person	10
Theater Indoor	Seat	5
Drive-in	Car space	10

Note: Unit flow rates published in standard texts, literature sources, or relevant area or regional studies are considered by the Department, if appropriate to the project.

DISPOSAL FIELD DESIGN/CONFIGURATION

Trench, Bed or Chamber Cross-section

PROJECTED SEWAGE FLOW: _____ g.p.d. / SOIL ABSORPTION RATE (SAR): _____

ABSORPTION AREA: _____

Trench Configuration

Please indicate vertical depths using inches.

- A. Backfill to final grade _____
 A-1 [Graded soil area, state using a (-) sign] _____
 A-2 [Fill or topsoil, state using a (+) sign] _____
- B. Distribution pipe w/ 2" of rock _____
- C. Aggregate depth (effective depth) _____
- D. Total trench depth _____

Trench width _____

Total length of trench _____ (ft.)

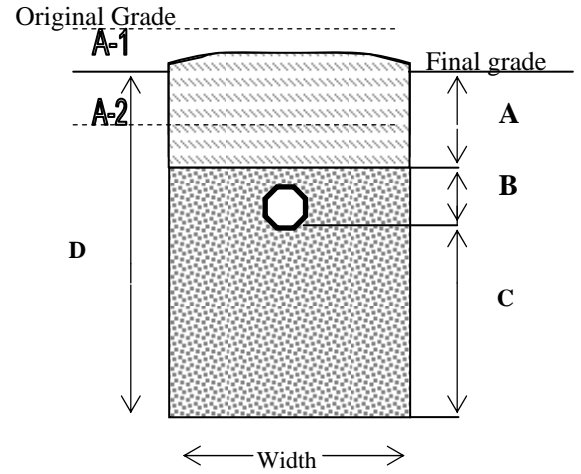

Gravity Beds

- A. Backfill _____
- B. Distribution line with 2" of aggregate material _____
- C. Aggregate depth _____
- D. Total Bed depth _____
 (Gravity Bed **shall** be less than 5' total depth)

Trench width 10' or 12' (circle one)

Distance between pipes 4' or 6' (circle one)

Total length of Bed _____

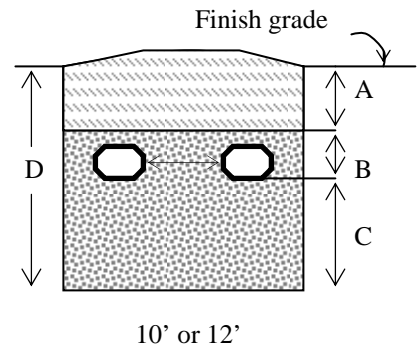

Infiltrator Chamber Worksheet

FIXTURE COUNT CALCULATION CHART

FIXTURE TYPE	UNIT		# OF FIXTURES		TOTAL FIXTURE UNITS
Bath Tub	2	X		=	
Bidet	2	X		=	
Clothes Washer	2	X		=	
Dishwasher (separate from kitchen)	2	X		=	
Lavatory (bathroom sink), single	1	X		=	
Lavatory, double in master bedroom	1	X		=	
Shower, single stall	2	X		=	
Sink, bar	1	X		=	
Sink, kitchen (including dishwasher)	2	X		=	
Sink, service	3	X		=	
Utility Tub or Sink	2	X		=	
Water Closet (toilet), 1.6 GPF	3	X		=	
Water Closet (toilet), >1.6 – 3.2 GPF	4	X		=	
Water Closet (toilet), >3.2 GPF	6	X		=	
TOTAL FIXTURE UNITS:					

Items in BOLD are the most commonly used fixtures

"Bedroom" means, for the purposes of determining design flow for an on-site wastewater treatment facility for a dwelling, any room that has:

- a) Floor space of at least 70 square feet in area, excluding closets;
- b) Ceiling height of at least 7 feet;
- c) Electrical service and ventilation;
- d) A closet or an area where a closet could be constructed;
- e) At least one window capable of being opened and used for emergency egress; and
- f) A method of entry and exit into the room which allows it to be considered distinct from other rooms in the dwelling to afford a level of privacy customarily expected for such a room.

Bedroom/Equivalent Worksheet	
Room Type	Number of Rooms
Bedroom	
Den	
Office	
Other:	
Other:	
Other:	
Total:	

TYPE OF CHAMBER (ÔPÔÔS ONE):	QUICK4 PLUS STANDARD LP	QUICK4 HIGH CAPACITY	ARC 36LP	ARC 36 HC
TANK SIZE (from Septic System Sizing Chart)	=	_____		
DESIGN FLOW (from Septic System Sizing Chart)	=	_____		
PERCOLATION RATE (from the Soils Report or Disposal Area Calculation Table)	=	_____		
SOIL ABSORPTION RATE (from the Soils Report or Disposal Area Calculation Table)	=	_____		
TOTAL SQUARE FOOTAGE REQUIRED (divide DESIGN FLOW by SAR or use Design Flow Calculation Table)	=	_____		
<ul style="list-style-type: none"> • QUICK4 PLUS STANDARD LP divisor is 24.62 per unit • QUICK4 HIGH CAPACITY divisor is 28.40 per unit • ARC 36LP divisor is 29.75 per unit • ARC 36 HC divisor is 34.43 per unit 				
DIVISOR USED (provided and recommended by manufacturer)	=	_____		
TOTAL NUMBER OF CHAMBERS (divide the TOTAL SQUARE FOOTAGE by the DIVISOR)	=	_____		
TOTAL LINEAR LENGTH OF TRENCH REQUIRED (multiply NUMBER of CHAMBERS by CHAMBER LENGTH: QUICK 4 = 4', ARC 36 = 5' per chamber)	=	_____		

Proposed Number of Trenches	_____
Proposed Number of Chambers per Trench	_____
Proposed Width of each Trench	_____
Proposed Length of each Trench	_____
Proposed Overall Depth of each Trench	_____
Separation Between Trench Edges	_____

- The maximum length for any disposal field is 100'. If the total linear length of trench is greater than 100', use a distribution box to divide the total length into multiple trenches of equal length to distribute the effluent more effectively throughout the disposal field.
- The separation between the chamber trench walls is a minimum of 5'.
- For contoured installations, chambers can swivel up to 10 degrees, left or right.

Permit/File #:

Designed by:

Date:

Prinsco Chamber Worksheet

FIXTURE COUNT CALCULATION CHART

FIXTURE TYPE	UNIT		# OF FIXTURES		TOTAL FIXTURE UNITS
Bath Tub	2	X		=	
Bidet	2	X		=	
Clothes Washer	2	X		=	
Dishwasher (separate from kitchen)	2	X		=	
Lavatory (bathroom sink), single	1	X		=	
Lavatory, double in master bedroom	1	X		=	
Shower, single stall	2	X		=	
Sink, bar	1	X		=	
Sink, kitchen (including dishwasher)	2	X		=	
Sink, service	3	X		=	
Utility Tub or Sink	2	X		=	
Water Closet (toilet), 1.6 GPF	3	X		=	
Water Closet (toilet), >1.6 – 3.2 GPF	4	X		=	
Water Closet (toilet), >3.2 GPF	6	X		=	
TOTAL FIXTURE UNITS:					

Items in BOLD are the most commonly used fixtures

"Bedroom" means, for the purposes of determining design flow for an on-site wastewater treatment facility for a dwelling, any room that has:

- a) Floor space of at least 70 square feet in area, excluding closets;
- b) Ceiling height of at least 7 feet;
- c) Electrical service and ventilation;
- d) A closet or an area where a closet could be constructed;
- e) At least one window capable of being opened and used for emergency egress; and
- f) A method of entry and exit into the room which allows it to be considered distinct from other rooms in the dwelling to afford a level of privacy customarily expected for such a room.

Bedroom/Equivalent Worksheet	
Room Type	Number of Rooms
Bedroom	
Den	
Office	
Other:	
Other:	
Other:	
Total:	

TYPE OF CHAMBER (ÓΠÒÓΣ ONE):

PRINSCO PRO436LP

PRINSCO PRO436

PRINSCO PRO436HC

TANK SIZE (from Septic System Sizing Chart)

= _____

DESIGN FLOW (from Septic System Sizing Chart)

= _____

PERCOLATION RATE

(from the Soils Report or Disposal Area Calculation Table)

= _____

SOIL ABSORPTION RATE

(from the Soils Report or Disposal Area Calculation Table)

= _____

TOTAL SQUARE FOOTAGE REQUIRED

(divide DESIGN FLOW by SAR or use Design Flow Calculation Table)

= _____

- [Prinsco Pro436LP](#) divisor is **24.73** per unit
- [Prinsco Pro436](#) divisor is **26.07** per unit
- [Prinsco Pro436HC](#) divisor is **28.53** per unit

DIVISOR USED (provided and recommended by manufacturer)

= _____

TOTAL NUMBER OF CHAMBERS (divide the TOTAL SQUARE FOOTAGE by the DIVISOR)

= _____

TOTAL LINEAR LENGTH OF TRENCH REQUIRED (multiply NUMBER of CHAMBERS by CHAMBER LENGTH: Prinsco Pro436 = 4' per chamber)

= _____

Proposed Number of Trenches	_____
Proposed Number of Chambers per Trench	_____
Proposed Width of each Trench	_____
Proposed Length of each Trench	_____
Proposed Overall Depth of each Trench	_____
Separation Between Trench Edges	_____

- The maximum length for any disposal field is 100'. If the total linear length of trench is greater than 100', use a distribution box to divide the total length into multiple trenches of equal length to distribute the effluent more effectively throughout the disposal field.
- The separation between the chamber trench walls is a minimum of 5'.
- For contoured installations, chambers can swivel up to 10 degrees, left or right.

EZflow EPS Aggregate System Worksheet

FIXTURE COUNT CALCULATION CHART

FIXTURE TYPE	UNIT	X	# OF FIXTURES	=	TOTAL FIXTURE UNITS
Bath Tub	2	X		=	
Bidet	2	X		=	
Clothes Washer	2	X		=	
Dishwasher (separate from kitchen)	2	X		=	
Lavatory (bathroom sink), single	1	X		=	
Lavatory, double in master bedroom	1	X		=	
Shower, single stall	2	X		=	
Sink, bar	1	X		=	
Sink, kitchen (including dishwasher)	2	X		=	
Sink, service	3	X		=	
Utility Tub or Sink	2	X		=	
Water Closet (toilet), 1.6 GPF	3	X		=	
Water Closet (toilet), >1.6 – 3.2 GPF	4	X		=	
Water Closet (toilet), >3.2 GPF	6	X		=	
TOTAL FIXTURE UNITS:					

Items in BOLD are the most commonly used fixtures

"Bedroom" means, for the purposes of determining design flow for an on-site wastewater treatment facility for a dwelling, any room that has:

- a) Floor space of at least 70 square feet in area, excluding closets;
- b) Ceiling height of at least 7 feet;
- c) Electrical service and ventilation;
- d) A closet or an area where a closet could be constructed;
- e) At least one window capable of being opened and used for emergency egress; and
- f) A method of entry and exit into the room which allows it to be considered distinct from other rooms in the dwelling to afford a level of privacy customarily expected for such a room.

Bedroom/Equivalent Worksheet

Room Type	Number of Rooms
Bedroom	
Den	
Office	
Other:	
Other:	
Other:	
Total:	

TRENCHES HAVE A MAXIMUM OVERALL DEPTH OF FIVE (5) FEET ABOVE DEPTH OF TEST HOLE

TANK SIZE (from Septic System Sizing Chart) = _____

DESIGN FLOW (from Septic System Sizing Chart) = _____

PERCOLATION RATE
(from the Soils Report or Disposal Area Calculation Table) = _____

SOIL ABSORPTION RATE
(from the Soils Report or Disposal Area Calculation Table) = _____

TOTAL SQUARE FOOTAGE REQUIRED
(divide DESIGN FLOW by SAR or use Design Flow Calculation Table) = _____

EZFLOW CONFIGURATION
(refer to EZFLOW Design Table; select from drop down list) = _____

DIVISOR USED (refer to EZFLOW Design Table) = _____

TOTAL LINEAR LENGTH OF TRENCH REQUIRED (divide TOTAL SQUARE FOOTAGE by DIVISOR) = _____

Proposed Number of Trenches	_____
Proposed Length of each Trench	_____
Proposed Width of each Trench	_____
Proposed Overall Depth of each Trench	_____
Separation Between Trench Edges	_____

- The maximum length for any disposal field is 100'. If the total linear length of trench is greater than 100', use a distribution box to divide the total length into multiple trenches of equal length to distribute the effluent more effectively throughout the disposal field.
- The separation between the trench walls is a minimum of 5' or twice the effective depth, whichever is greater.

Permit/File #:

Designed by:

Date:

ON-SITE WASTEWATER SYSTEM PLOT PLAN

(for 4.02 General Permit only. 4.02-4.22 must provide construction quality drawings)

Address:	<input type="checkbox"/> North Arrow shown
Assessor Parcel:	<input type="checkbox"/> Boundaries of property shown on plan
Legal Description:	<input type="checkbox"/> Proposed/existing systems, dwellings, buildings, driveways, swimming pools, tennis courts, wells, ponds, and any paved, concrete or water feature, shown.
	<input type="checkbox"/> Slopes and cut banks greater than 15%, retaining walls and other constructed features shown
	<input type="checkbox"/> Any feature less than 200 ft. from facility and reserve area that constrains the location due to setback limitations shown
	<input type="checkbox"/> Topography shown with contour intervals, showing original and post-installation grades
Property Size (in acres):	<input type="checkbox"/> EXACT LOCATION of all soils testing and percolation sites
Engineer's Scale (max 1"=60'):	<input type="checkbox"/> Location of the treatment and disposal works, pipelines, reserve area
Permit Number:	<input type="checkbox"/> Location of any public sewer if less than 400 ft. from property line

Proper construction and installation of this system shall follow all applicable Federal, State, County and City laws. Mohave county disclaims any responsibility of the construction, installation, errors or omissions involved with this system and the sole responsibility for any of the above is with the owner or his/her contractor (s) and/or agents (s). The as-built drawing is provided for ease and convenience to locate the system in the future and not for construction purposes.

The information within the plot plan submitted is true and accurate to the best of my knowledge;

Signature

Title

Date: _____



MOHAVE COUNTY DEVELOPMENT SERVICES

P. O. Box 7000 Kingman, Arizona 86402-7000 3250 E. Kino Ave, Kingman www.mohave.gov Telephone (928) 757-0903

SEWER AVAILABILITY INFORMATION SHEET

Service Provider/Company Name:	Submitted by:
	Telephone:
	Fax:

Date:

Name of Property Owner:

Location Address:

Subdivision:	Tract:	Block:	Lot:
--------------	--------	--------	------

Assessor Parcel Number:

Indicate below what type of project will be constructed on the above mentioned property:

<input type="checkbox"/> Residential (Single Family Only)	
<input type="checkbox"/> Commercial/Multi-family	Estimate flow rate in gallons per day:
<input type="checkbox"/> Industrial	Estimate flow rate in gallons per day:

Flood Zone:

Applicant Signature:

Per an inquiry with the above-referenced service provider regarding the availability of sanitary sewer to serve the above-referenced location, sewer is available at property:

- Yes, sewer is available and will be connected to
- No, sewer connection exceeds fees of R18-9-A309(A)(5)(b) (Engineers/Contractor's Estimate req.)
- N/A, no sewer service provider in subdivision

DISCLAIMER: For North Kingman / New Kingman Addition / Butler: if property is greater than 100' but less than 500' from City of Kingman Sewer, opting to use on an onsite wastewater system may result in the City of Kingman denying water service should an existing water meter not exist on the property at the time of septic permit issuance.

Does this property have an existing water meter: YES NO

Distance to sewer: **feet**

Comments: _____

Sewer Provider Representative Signature:



MOHAVE COUNTY DEVELOPMENT SERVICES

P. O. Box 7000 Kingman, Arizona 86402-7000 3250 E. Kino Ave, Kingman www.mohave.gov Telephone (928) 757-0903

Scott Holtry
Department Director

J. David Strahl
County Manager

TO: SANITARY DISTRICT OR UTILITY COMPANY

TEMPORARY INDIVIDUAL WASTE DISPOSAL SYSTEM

I, _____, Owner of property located in the _____ Subdivision, Tract _____, Block _____, Lot _____, Address _____, Arizona, understand that the sewage disposal system to be installed to service my residence located on the above described property is a temporary system. I, hereby agree to abandon such system in a method approved by the local Environmental Quality Department, and connect to municipal sewer system servicing our location; subject to the requirements of R18-9-A309.A.5

The Mohave County Development Services Department, Environmental Quality/Waste Management Division is to be notified prior to abandonment of the system.

TEMPORARY PERMIT # _____ ASSESSOR'S PARCEL # _____

SIGNATURE OF PROPERTY OWNER

DATE

ARIZONA DEPT. OF ENVIRONMENTAL QUALITY

DATE

MOHAVE COUNTY ENVIRONMENTAL QUALITY/
WASTE MANAGEMENT REPRESENTATIVE

DATE